



SCHOTT's PYRAN® S borosilicate glass is the ideal material for this structural application due to its reduced thermal expansion and inherent resistance to fire.



### PYRAN® S from SCHOTT

SCHOTT, Europe's leading specialist glass manufacturer has produced PYRAN® fire resistant glass for over 25 years. With a proven international test portfolio in increasingly innovative structures, PYRAN® S leads the way in integrity rated fire resistant systems. PYRAN® S is a monolithic toughened glass. Its unique borosilicate composition enables the glass to resist high temperatures and temperature differentials. The rate of expansion of PYRAN® S is only one third that of sodium silicate glasses, making it ideal for structural glazing applications where expansion and movement of the glass and supporting structures are critical.

PYRAN® S is also available with screen printing and sandblasting. For technical details and further information please contact your local SCHOTT office.

### At a glance

Type of glass	float, fully toughened borosilicate glass
Test report	38010502
Fire rating	30 minutes integrity
Max tested pane size	1200 mm x 3000 mm
Thickness	8, 10, 12 mm
Brackets	steel or stainless steel
Sealant	white, grey, black, dark brown or olive
Point supports	stainless steel

**SCHOTT UK Ltd**  
 Sales Office  
 Drummond Road  
 Stafford ST16 3EL  
 United Kingdom  
 Phone: +44 (0)1785/223166  
 Fax: +44 (0)1785/223522  
 E-mail: [info.uk@schott.com](mailto:info.uk@schott.com)  
[www.schott.com/uk](http://www.schott.com/uk)

**SCHOTT**  
 glass made of ideas



## SCHOTT PYRAN® S

Fire Resistant Structural Glazing System

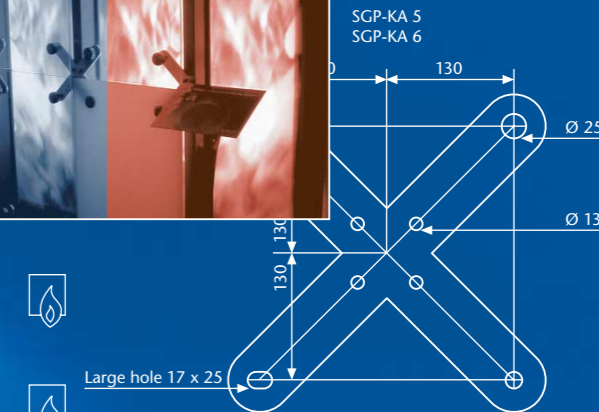

20131 e 0204 2.0 ballie Printed in Germany

**SCHOTT**  
 glass made of ideas

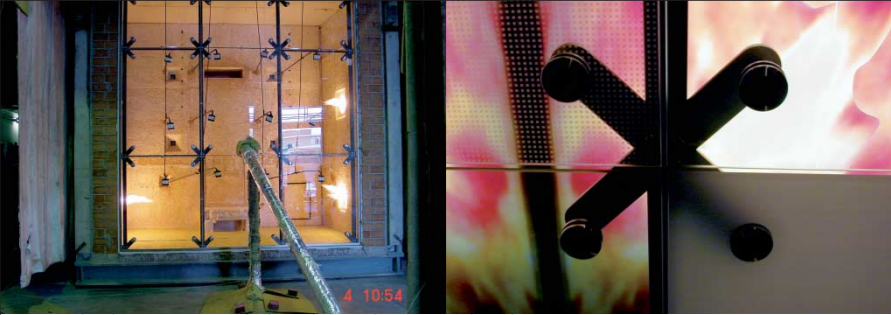

# SCHOTT PYRAN® S

## Fire Resistant Structural Glazing System

### 30 minutes integrity

Traditional fire rated structural glazing systems require mullion and transom constructions which can be obtrusive and detract from the natural transparency of glass. As a result, architects and designers have to compromise their designs where fire protection is necessary.

This no longer has to be the case as proven by the innovative PYRAN® S Structural Glazing System from SCHOTT.

### The Concept

The SCHOTT Structural Glazing System offers a frameless construction supported by steelwork behind the glass facade and a series of brackets. The joints between the PYRAN® S glass panels are filled with Fireglaze intumescent compound from Sealmaster Ltd.

The glass panes may be connected in portrait or landscape format in maximum dimensions up to 1200 mm x 3000 mm.

The panes are fixed back to the supporting steelwork with special fixings and brackets.

- Under normal construction conditions the point support fixings carry the full weight of the glass panes without creating any additional stresses on the drilled area of the glass.
- Even during extreme movements caused in a fire situation the point support fixings provide pressure free support of the glass.

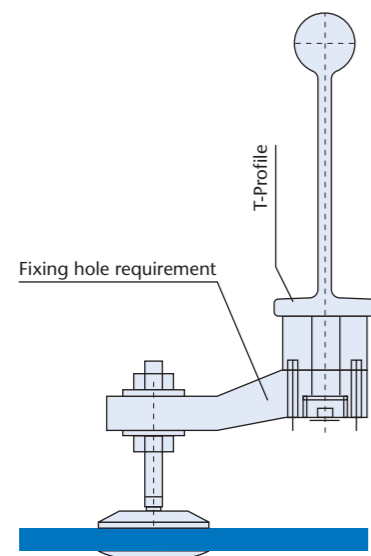

### System components

#### T-Profiles:

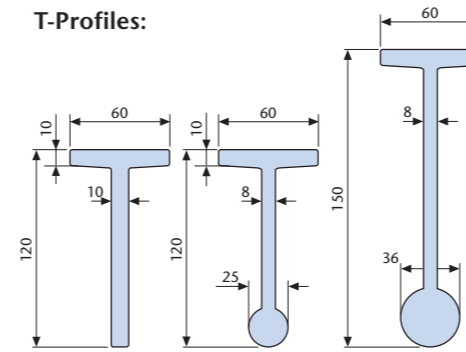

These T-Profiles are typical of the support steelwork.

#### Point support fixings:

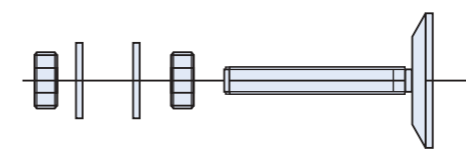

#### Stainless steel brackets

The connection of the brackets to the glass is designed in such a way that no excessive movement can occur. Ball joints in the point assembly allow for full deflection of the glass panes during exposure to positive and negative air pressures.

A combination of fixed and moveable attachment points within each bracket allows independent movement between the support construction and the glazing. The glass panes are hung from the upper holes and then securely fixed at one corner so that movement is taken up by the remaining fixings.

#### Fixing hole requirements:

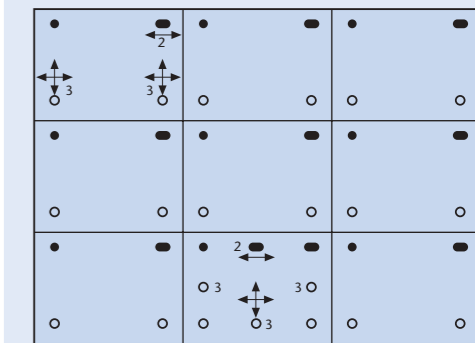
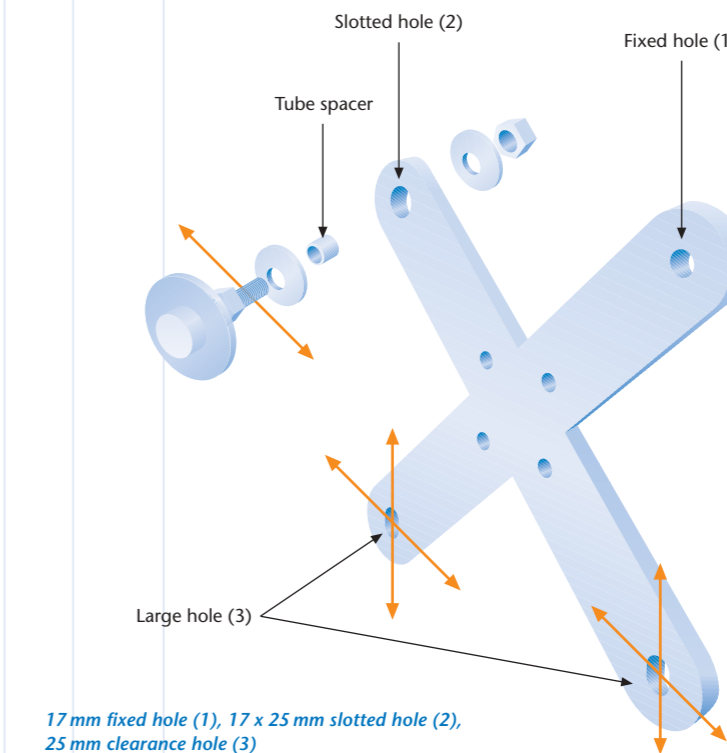

Typical cross section



With this innovation SCHOTT is responding to the demands of 21st century architecture by making glass even more versatile. It is now possible to design partitions and atria walling incorporating fire resistant glass with this exciting development.